

SkyTrim 75 G2

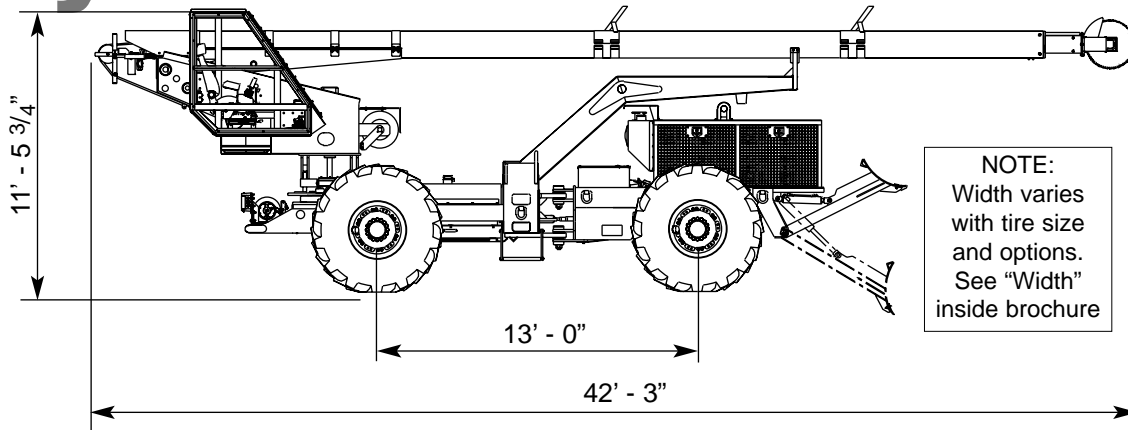

Description: The SkyTrim is a rough terrain, rubber-tired vehicle with telescoping boom and saw-type cutter head designed to trim trees.

Frame: Welded construction front and rear main frames. High-strength alloy steel superstructure.

Weight: Approximately 24,300 lbs with std. tires.

Engine: Equipped with liquid-cooled 4.4 liter Caterpillar® diesel engine rated for 127 hp @ 2200 rpm. Open engine compartment for maximum accessibility with light weight composite doors.

Propel System: Hydrostatic 4-wheel drive with propel motor driving through a heavy-duty 2-speed powershift transmission.

Transmission and Axles: 2-speed shift-on-the-go transmission connected by heavy-duty drive shafts to both axles. Heavy-duty Caterpillar® axles with inboard wet disc service brakes. Rear axle is rigid mounted, front axle designed to oscillate.

Wheels, Tires and Brakes: Tires: 28L-26 logger type tire standard. Wheels are adjustable to change track width. Service brakes are wet disc inboard hydraulically applied and "built-in" the axles. Parking brakes are fail-safe spring-applied/hydraulic-released wet disc drive-line mounted. Parking brakes will automatically apply and stop machine if engine stops.

Hydraulic System: Engine driven pump drive. Hydrostatic propel system consists of closed loop pump driving a hydraulic propel motor mounted on transmission. Charge loop filtration. Hydraulic reservoir mounted outside engine compartment with cleanout port and shutoff valve. Equipped with electric emergency pump. Upperstructure tilt system and boom up/down system equipped with lock valves.

Electrical System: 12 volt dc negative ground with engine driven alternator and two 12-volt batteries w/950 cold cranking amps each. Equipped with safety electric strobe light.

Capacities: Fuel: 60 gal. Hydraulic: 30 gal.

Cab: Equipped with 1 1/4" tinted Lexgard® top, engine instruments, and ergonomic seat. Equipped with light touch hydraulic pilot pressure joystick for extend-lift-swing-tilt boom controls. Heavy duty swing bearing with worm gear drive for maximum tooth engagement. Floor is fully enclosed. Back is fully enclosed with safety tinted Lexgard®. Access door is full length tinted Lexgard® with positive latch. Optional fully enclosed cab with heater and air conditioner available.

Boom: Telescoping composite construction with 75 ft. reach from ground. Telescoping boom driven with #50 chain. Each unit is electrically insulated and tested to ANSI A92.2-2001 Category C standards to 100 kv for maximum operator safety. Equipped with single 24 inch diameter carbide-tipped saw turning @ 2800 rpm.

Optional Equipment: Front mounted winch. Optional tire sizes. Air conditioner & heater with enclosed cab. Other options available upon request.

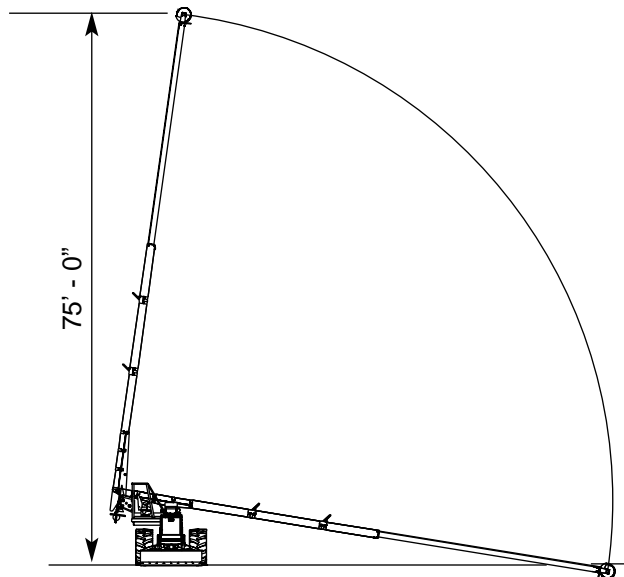

www.kershawusa.com

Printed in U.S.A. June 2008

KERSHAW
a division of Progress Rail Services

P. O. Box 244100
Montgomery, AL 36124
Telephone (334) 387-9100
Fax (334) 387-9375

**ISO 9001:2000
REGISTERED**