



PR30C Technical Details

PR30C Benefits

- EPA Tier2 Emissions Basic
- Optional Exhaust Aftertreatment for Tier3 with Tier4 NOx
- 5-15% + Fuel Savings vs. Comparable Originally Equipped Locomotives
- Durable Caterpillar 3516 Engine for Years of Reliable Service
- 184 Day Maintenance Cycle at EPA Tier2

Dimensions and Performance

- AAR Clearance - Plate L
- Nominal Length 68' 10"
- Nominal Weight 400,000 lbs
- Stall Tractive Effort (estimate) - 120,000 lbs
- Continuous Tractive Effort - 83,000 lbs
- Dynamic Brake max. - 58,000 lbs

Engine Model	3516C-HD
Locomotive Gross Power	3005 hp
Wheel Arrangement	C - C
Total Engine Oil	216 gallons
Total Engine Coolant	121 gallons
Traction Alternators	Marathon
Traction Motors	D77 type
Air Compressor	GAR37
Air Brake (basic)	26L/CCB26
Fuel Tank (nominal)	3200 gallons
Basic EPA Compliance	Tier 2
with Exhaust Aftertreatment	Tier 3
(pending final EPA certification)	Tier 4

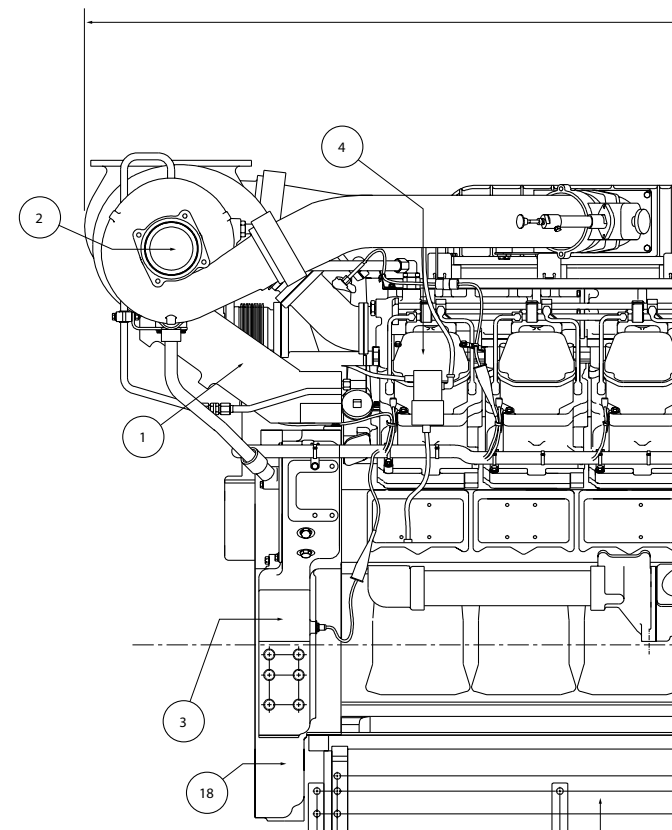
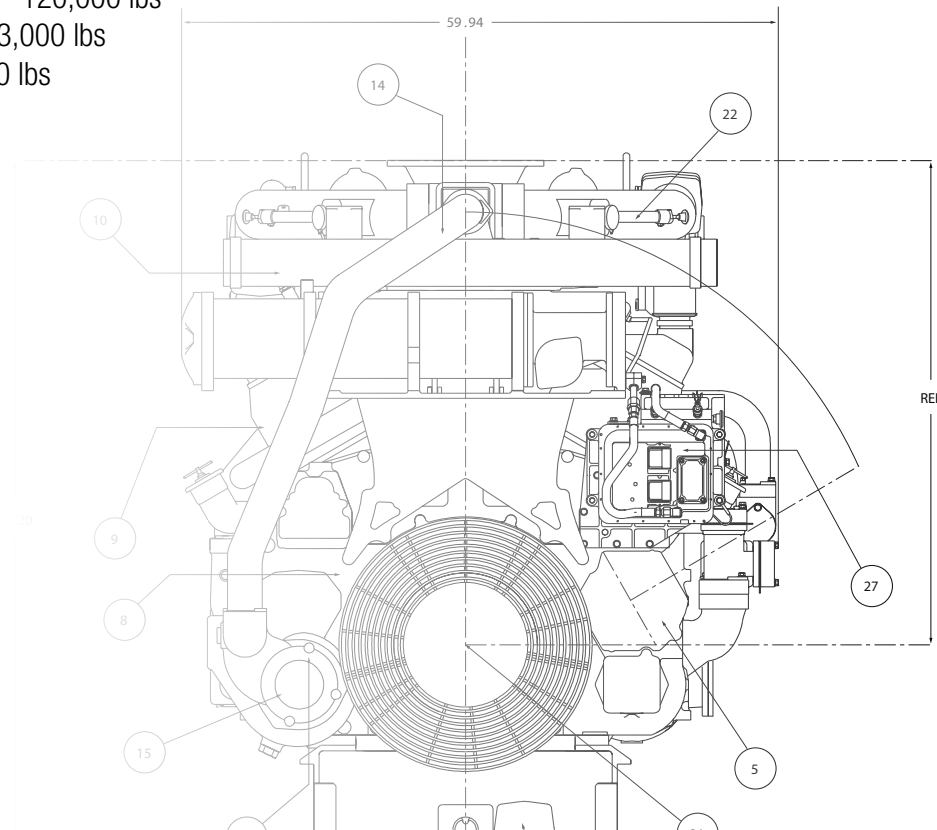

Engine Shown May Not Reflect Actual Engine Used.