

KlearWay 500

NOTE:

Width: 8' - 6" w/23.1 Tires
Width: 9' - 0" w/28L Tires
Height Shown Is With 23.1
Tires. Height With 28L
Tires Is 10' - 9"

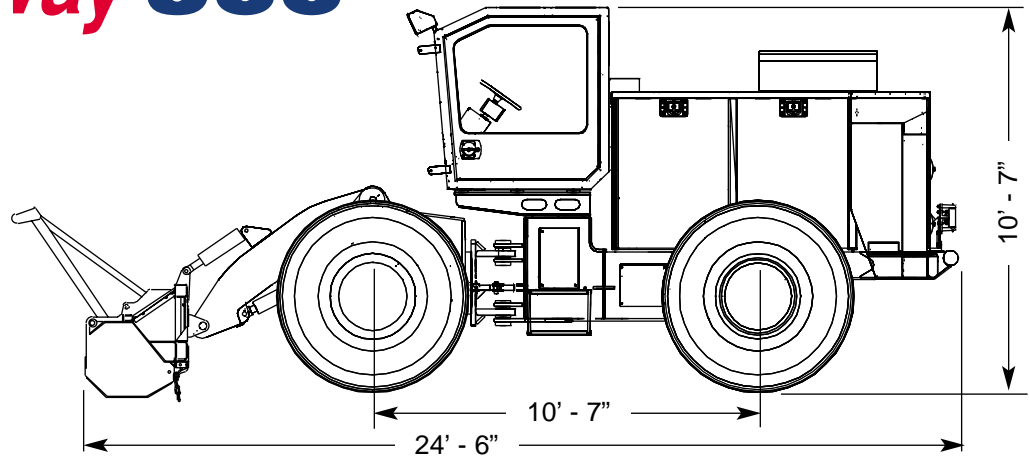

Description: The Klearway 500 is a rough terrain, rubber-tired vehicle with a front mounted rotary or shredder-type cutterhead designed to clear vegetation from utility right-of-ways, railroad right-of-ways and for site preparation.

Frame: Consists of welded construction front and rear main frames with structural tubing and fabricated side members. Front and rear frames are connected by an articulating joint allowing 15 degrees of up or down oscillation and 50 degrees right or left power steering action.

Weight: Approximately 26,000 lbs with standard 23.1 tires and rotary cutterhead. 28,000 w/shredder-type cutterhead.

Engine: Equipped with Caterpillar® C6.6 liquid cooled diesel engine rated for 202 bhp @ 2200 rpm. Engine equipped with exhaust muffler and large capacity cooling system.

Propel System: Hydrostatic 4-wheel drive with propel motor driving through a heavy-duty 2-speed powershift transmission.

Transmission and Axles: 2-speed shift-on-the-go transmission connected by heavy-duty Dana-Spicer 1550 drive shafts to both axles. Heavy-duty Caterpillar® axles with wet disc service brakes. Rear axle has no-spin differential and front axle is limited slip.

Wheels, Tires and Brakes: Tires: 23.1-26 10-ply logger type tire standard. Service brakes are inboard wet disc type. Parking brake is driveline-mounted fail-safe spring applied/hydraulic released wet disc.

Hydraulic System: Engine driven pump drive. Loadsense control hydraulic system. Hydrostatic propel system consists of closed loop pump driving a hydraulic propel motor mounted on transmission. Charge loop filtration. Hydraulic reservoir mounted outside engine compartment with cleanout port and shutoff valve. Cutterhead hydraulic circuits consist of two closed loop hydrostatic systems with variable displacement pumps and fixed displacement motors.

Electrical System: 12 volt dc negative ground with engine driven 100 amp alternator and two 12-volt batteries w/950 cold cranking amps each.

Cab: Angled front roof profile equipped with 1 1/4" thick tinted Lexan roof viewing window. Equipped with hydraulic joystick control for cutterhead lift and tilt functions. Fully enclosed cab with heater and air conditioner. Tilt steering wheel uses flow amplification to produce a variable oil flow to steering cylinders in relation to steering wheel speed. Fully adjustable seat with suspension, seat belts and lumbar support. Front windshield wiper, dome light, Lexan windows, front window guard, electric horn and full engine instrumentation are standard.

Travel Speed: Low range: 4.4 mph, high range: 16.6 mph w/ 23.1 tires.

Capacities: Fuel tank: 81 gallons. Hydraulic tank: 70 gallons.

Ground Clearance: With 23.1 tires: 21". With 28L26 tires: 23".

Optional Equipment: Optional tire sizes: 23.1x26, 28L26 or 67x34.00-25. Rotary twin disk cutterhead or shredder-type cutterhead. Other options available upon request.



P. O. Box 244100
Montgomery, AL 36124

Telephone (334) 387-9100
Fax (334) 387-9375

ISO 9001:2000
REGISTERED